

CAPACITANCE TYPE LEVEL SWITCH Model **ALN/SL**



Our continuous product improvement has got highly stable & reliable detection come true. ALN/SL can be the best selling line with some possible improvements added in the years to come.

ALN/SL

CAPACITANCE TYPE LEVEL SWITCH

ABUNDANT EXPERIENCE &

OUR ACHIEVEMENTS IN THE MARKET

OUR PRIMARY PRODUCT, ALL-PURPOSE

LEVEL SWITCH, BASED ON OUR EXCELLENT TECHNOLOGY



IN ACCORDANCE WITH VARIOUS APPLICATIONS, WE CAN PROVIDE WITH VARIOUS ELECTRODES THAT FALL INTO 1000 CATEGORIES AND WITH SPECIAL CIRCUIT.



Standard Type
Straight Electrode

Ultra Heatproof Type,
Straight Electrode

Heat-resistant Type,
Straight Electrode

Teflon coating Type,
Straight Electrode

Teflon coating Type,
Flared Straight Electrode

High-sensitivity Type,
Straight Electrode

Super-sensitivity Type,
Straight Electrode



DETECTING LEVEL OF MANY PRODUCTS INCLUDING POWDER, GRANULES, LUMP, LIQUID, PASTE, AND FOAM.

FEATURES

- Operate reliably in face of fouling and build-up.
- Can be used for measuring highly conducting materials.
- Can easily detect highly corrosive substance.
- Highly sensitive and stable meter.
- This excels in mechanical intensity and durability.
- Can easily install and adjust.

PRINCIPLE OF OPERATION

This measures the impedance variation coming out between a main electrode and a tank-wall or between the main electrode and an earth electrode. As the level rises, the capacitance value goes up, and it provides a contact output when the level exceeds the set value.

W12



W8-B1



F1



Standard Type
Flat Electrode

B1-IN



IDF Mounting Type,
Straight Electrode

B1-IF



Ferrule-mounting Type,
Straight Electrode

Withstand load Type,
Wire Electrode

Standard Type
Wire Electrode

F27



Flat Electrode
with Earthing Electrode

L1



Standard Type
Pipeline Electrode



ALN HIGHLY STABLE & RELIABLE DETECTION. OFFERS GUARANTEED SOLUTIONS EVERY APPLICATION

The Model ALN is the versatile Capacitance Type Level Switch that can detect the level of sediments in liquid, interface between two different liquids as well as the level of high-insulating powders/granules, conductive liquids/viscous liquids and others. It is one of the highly efficient detectors which Kansai Automation Co., Ltd. has developed to ensure a correct level detection under such conditions requiring the high technology as varied measuring materials, complex/harsh products and so on. Through our long-term experiences and achievements, use of quality materials and strict quality control, we have here provided you with more stable and more reliable products.

STANDARD SPECIFICATION

- Instrument Power Source : 105 / 210VAC ±10% 50/60Hz
 - Power Consumption : 4.5VA
 - Output Contact : SPDT, 250VAC 10A, 30VDC 10A
Resistive load
 - Ambient Temperature Allowance : -25°C~+60°C
 - Stable Detection Range : 1. High Sensitivity 0.5~20pF
2. Standard Sensitivity 2~50pF
3. Low Sensitivity 20~1,000pF
4. Ultra Low Sensitivity 5~35Ω
 - Delay Time Setting : Max.10 seconds, variable
 - Vibration : 2mm 600~ 3,600 /min
in all direction for three hours
 - Enclosure : IP66 equivalent
 - Painting Color : Gold
- As for ALN Type, a product with 24VDC can be ordered.

DELAY TIME SETTING

The output relay motion can be delayed continuously and variably by up to ten seconds from the time of detection. (the pilot lamp lights) Set the delay time by the setting Volume as required. When the wetted time is shorter than the set delay time, however, the output relay does not operate.

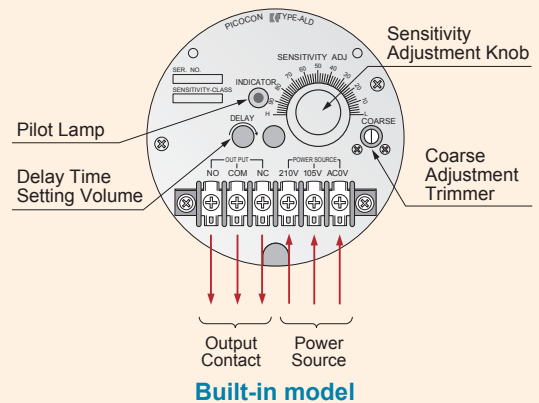

SPECIFICATION-PROBE

- (Standard Level Switch)
- Withstand Load at Electrode : Top End Load (≒ 250) 1kN (100kg)
- Withstand Pressure at Electrode : 980kPa
- Allowable Temperature at Electrode : -25°C~+80°C
- Impact : 9.8kGa (10G) at electrode

REMOTE AMPLIFIER MODEL



Separate box for outdoor use

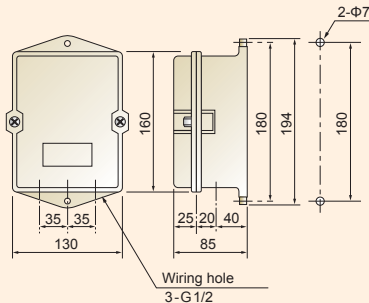

Separate box for indoor use

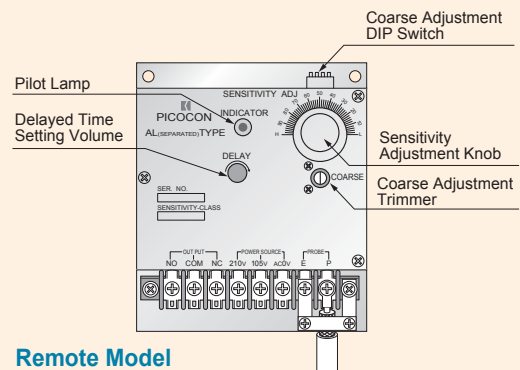
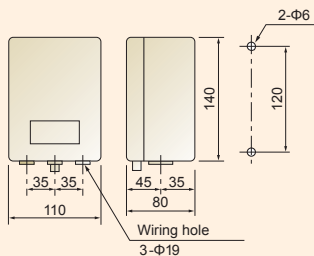

Remote Model

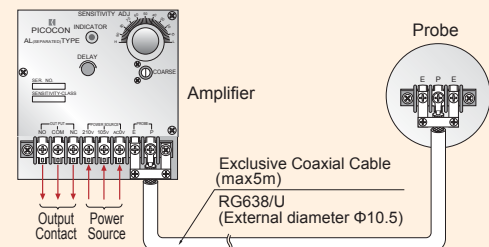

Wiring Diagram



SL

CERTIFIED AS INTRINSIC SAFETY EXPLOSION-PROOF CONSTRUCTION, CAN BE APPLIED TO EVERY SHAPE OF ELECTRODE.

**INTRINSIC SAFETY
EXPLOSION-PROOF
CONSTRUCTION
(i) 3nG5
LABOR INSPECTION
No.26358**

This type is one of the safest explosion-proof instruments to be applied in hazardous areas where Water Gas, Hydrogen, Carbon Disulfide and others exist. You can use it safely in such ambient atmospheres as all kinds of combustible gases and flammable liquids.

Certified according to Chinese Government as Explosion-proof.



STANDARD SPECIFICATION

Instrument Power Source : 105V / 210 VAC ±10% 50/ 60Hz

Power Consumption : 4 VA

Output Contact : SPDT 100VA (200VAC Max, 2A Max)

Stable Detection Range : 1. High Sensitivity 0.5~20pF
2. Standard Sensitivity 2~50pF
3. Low Sensitivity 20~1,000pF

Vibration : 2mm 600~3,600 / min
in all direction for three hours

Enclosure : IP66 equivalent

Painting Color : Gold

SPECIFICATION-PROBE

(Standard Level Switch)

Withstand Load at Electrode : Top End Load (t=250) 1kN (100kg)

Withstand Pressure at Electrode : 980 kPa

Ambient Temperature Allowance : -25°C~+80°C

Impact : 9.8kGa (10G) at electrode

REMOTE MODEL

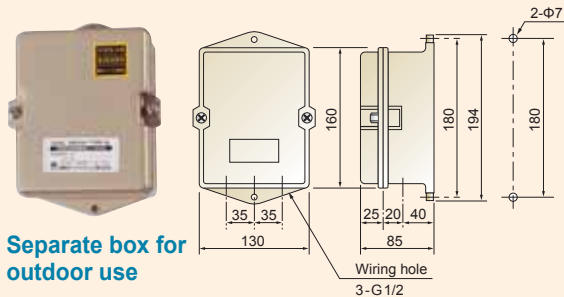

Separate box for outdoor use

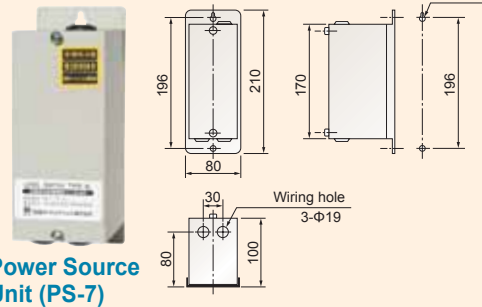

Power Source Unit (PS-7)

BUILT-IN MODEL

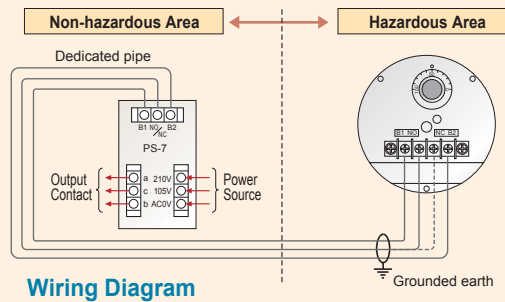
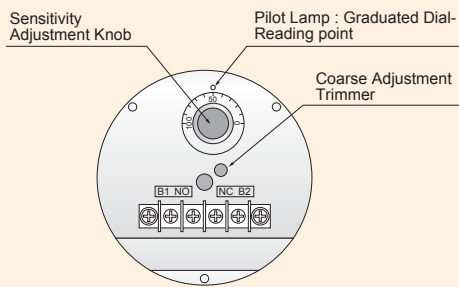

Wiring Diagram

REMOTE Model

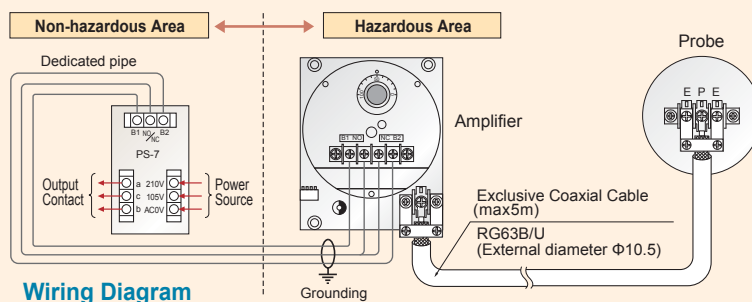
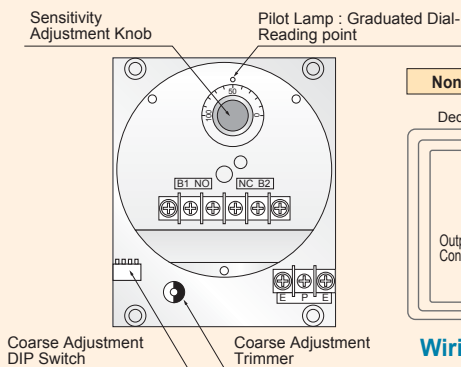

Wiring Diagram

Outline Drawing

B1



Standard Type, Straight Electrode

The length of electrode can arbitrarily be selectable to suit your application.

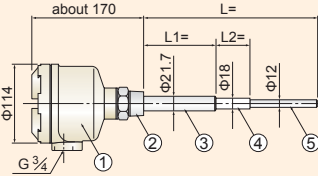

(B1)

No.	Parts Name	Material
1	Housing	ADC
2	Screw	304SS
3	Earth electrode	304SS
4	Insulator	Polyacetal
5	Electrode	304SS

B33



High-sensitivity Type, Straight Electrode

The shape can be selectable depending on the loading condition.

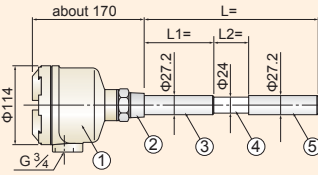

(B33)

No.	Parts Name	Material
1	Housing	ADC
2	Screw	304SS
3	Earth electrode	304SS
4	Insulator	Polyacetal
5	Electrode	304SS

B440



Super-sensitivity Type, Straight Electrode

It is effective in detecting low-dielectric-constant products.

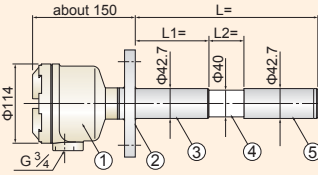

(B440)

No.	Parts Name	Material
1	Housing	ADC
2	Flange	304SS
3	Earth electrode	304SS
4	Insulator	Polyacetal
5	Electrode	304SS

B1·H1



Heat-resistant Type, Straight Electrode

Materials of insulator and gasket may be changed subject to temperature and products to be measured.

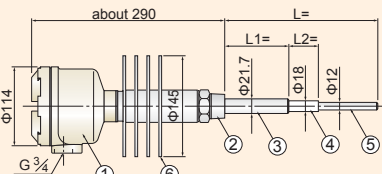

(B1· H1)

No.	Parts Name	Material
1	Housing	ADC
2	Screw	304SS
3	Earth electrode	304SS
4	Insulator	Teflon
5	Electrode	304SS
6	Fin	AC

B410-H3



Ultra Heat-resistant Type, Straight Electrode

The electrode can work with no problem in face of its metal elasticity due to temperature change.

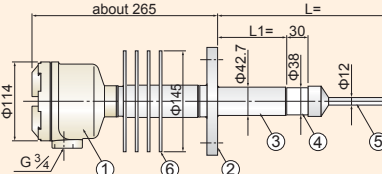

(B410-H3)

No.	Parts Name	Material
1	Housing	ADC
2	Flange	304SS
3	Earth electrode	304SS
4	Insulator	Ceramic
5	Electrode	304SS
6	Fin	AC

F1



Standard Type, Flat Electrode

Suitable for an agitation tank because it has no protruberance jut in a tank.

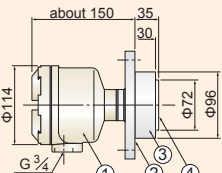

(F1)

No.	Parts Name	Material
1	Housing	ADC
2	Flange	304SS
3	Insulator	Polyacetal
4	Electrode	304SS

F27



Flat Electrode with Earthing Electrode

The advanced flat electrode comes up with Withstand load and Ultra sensitivity.

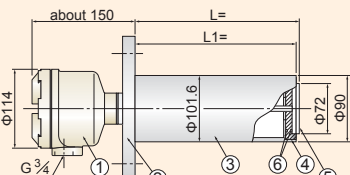

(F27)

No.	Parts Name	Material
1	Housing	ADC
2	Flange	304SS
3	Earth electrode	304SS
4	Insulator	Polyacetal
5	Electrode	304SS
6	O-ring	Silicon



Standard Type, Pipeline Electrode

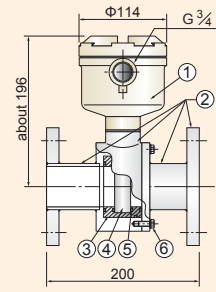

Manufacture as per order.
From teflon-coating to high sensitivity type.

(L1)

No.	Parts Name	Material
1	Housing	ADC
2	Earth electrode with flange	304SS
3	Insulator	Polyacetal
4	Electrode	304SS
5	O-ring	Silicon
6	Hexagon nut	304SS

Teflon coating Type, Straight Electrode

Suitable for viscous materials.
It may not be affected by fouling.

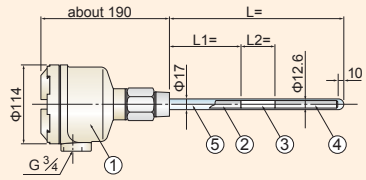

(P1-17)

No.	Parts Name	Material
1	Housing	ADC
2	Earth electrode	304SS
3	Insulator	Polyacetal
4	Electrode	304SS
5	Tube	Teflon

Teflon coating Type, Flared Straight Electrode

Complete Teflon-coating up to flange face. It is effective in detecting corrosive substance.

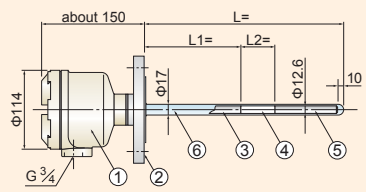

(P2-17)

No.	Parts Name	Material
1	Housing	ADC
2	Flange	304SS
3	Earth electrode	S304SS
4	Insulator	Polyacetal
5	Electrode	304SS
6	Tube	Teflon

Ferrule-mounting Type, Straight Electrode

Fixing by the ferrule.
Teflon-coating one can also be manufactured.

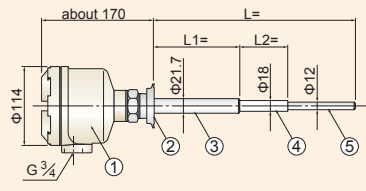

(B1-IF)

No.	Parts Name	Material
1	Housing	ADC
2	Ferrule	304SS
3	Earth electrode	304SS
4	Insulator	Teflon
5	Electrode	304SS

IDF Mounting Type, Straight Electrode

Fixing by the IDF nut.
Various shapes of electrode can be available.

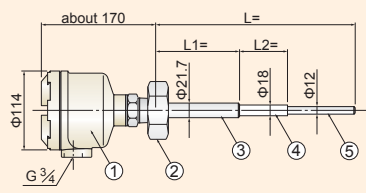

(B1-IN)

No.	Parts Name	Material
1	Housing	ADC
2	Union nut	304SS
3	Earth electrode	304SS
4	Insulator	Teflon
5	Electrode	304SS

Standard Type, Wire Electrode

Typical wire-type.
The wire length is adjustable in the field.

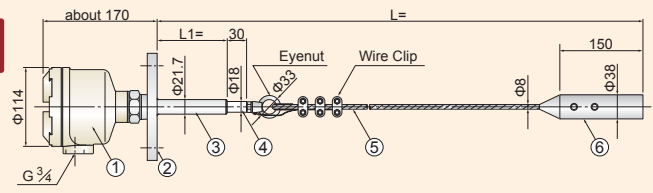

(W8-B1)

No.	Parts Name	Material
1	Housing	ADC
2	Flange	304SS
3	Earth electrode	304SS
4	Insulator	Polyacetal
5	Electrode wire	304SS
6	Weight	304SS

Withstand load Type, Wire Electrode

Well designed to stand for a heavy load at the bottom of a big silo.

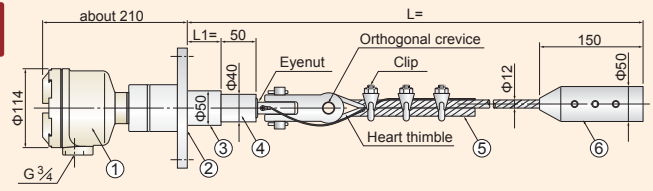

(W12)

No.	Parts Name	Material
1	Housing	ADC
2	Flange	SS400
3	Earth electrode	304SS
4	Insulator	Polyacetal
5	Electrode wire	304SS
6	Weight	304SS

DESIGNATION OF MODEL

ALN-□□□-□□

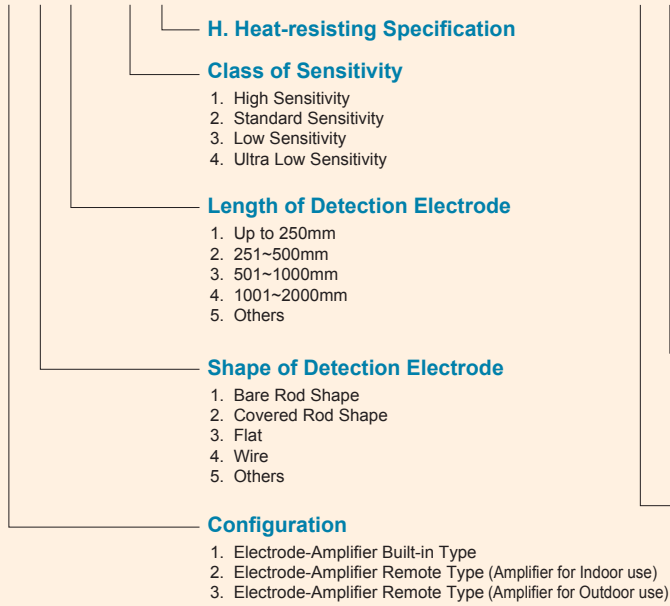

SL-□□□-□□

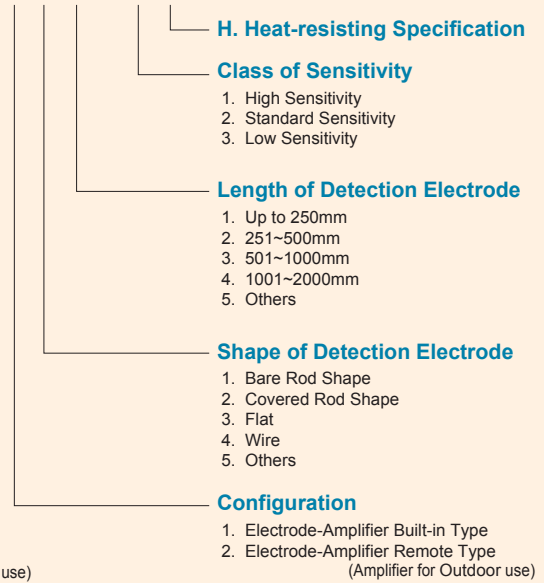

Please provide us with the following information when inquiring and ordering

1. Name of material to be measured	[]
2. Dielectric constant, conductivity	[]
3. Material	[Liquid • Powder (Granularity) • Slurry (cp)]
4. Tendency to buildup	[Yes • No]
5. Corrosive	[Yes • No]
6. Tank Materials	[]
7. Agitator etc.	[Yes • No]
8. Service Temperature	[°C
9. Service Pressure	[Pa
10. Detection Point	[Upper • Lower • etc]
11. Mounting	[Vertical • Horizontal • Tilt•etc]
12. Process Connection	[Flange • Screwed • etc]
13. Height of Standpipe	[mm
14. Electrode Length	[mm

SENSITIVITY

Model	Class	Dielectric Constant
ALN SL -□□□-1	High sensitivity (0.5~20PF)	1.5~7
ALN SL -□□□-2	Standard sensitivity (2~50PF)	7~80
ALN SL -□□□-3	Low sensitivity (20~1,000PF)	Over 70
ALN -□□□-4	Ultra low sensitivity (5~35Ω)	Resistance value 5~35Ω

INSTRUCTION ON SETTING

Earth electrode must be protruded at least 10mm, inside the tank if the buildup is heavy then more than 50mm.

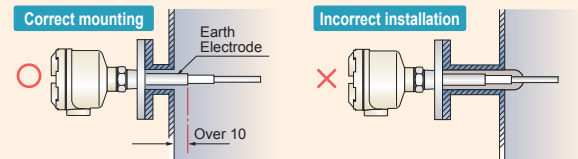

Line of business

- Rotary Paddle Type Level Switch
- Vibration Type Level Switch
- Swing Type Level Switch
- Acoustic Level Switch
- Capacitance Type Level Switch
- Capacitive Proximity Sensor
- Capacitance Type Level Indicator
- Diaphragm Type Level Switch
- Tilt Switch
- Leak Type Level Switch
- Microwave Switch
- Sounding Bob Type Level Indicator
- Flow Switch
- Conductance Type Level Switch
- Float Switch
- Float Type Level Indicator
- Ultrasonic Type Level Indicator
- Equipments For Conveyor Lines
- Dust Monitor System
- Zirconia Oxygen Analyzer
- Laser Type Level Indicator
- RADAR Type Level Indicator
- On-line Sensors for Accurate Liquid Analysis
- Ultrasonic Flow meter

*Please be sure to read USER'S GUIDE, Installation & Operation Instructions before using the instrument.

*The specifications herein may be subject to change without advance notice.

Nuclear Power Generation to Rice Milling
All-round Manufacturer of Level Controllers for Powder, Granules and Liquid

KANSAI Automation Co.,Ltd.

Headquarters :
2-14, Togano-cho, Kita-ku, Osaka 530-0056, Japan
TEL. 81-6-6312-2071 FAX. 81-6-6314-0848
e-mail: info@kansai-automation.co.jp

<http://www.kansai-automation.co.jp>

Tokyo Branch : 1-29-6, Hamamatsu-cho, Minato-ku, Tokyo 105-0013, Japan
TEL. 81-3-5777-6931 FAX. 81-3-5777-6933

Nagoya Office : 3-31-27, Uchiyama, Chigusa-ku, Nagoya 464-0075, Japan
TEL. 81-52-741-2432 FAX. 81-52-741-1588

Kyushu Office : 1-2-39, Asano, Kokura Kita-ku, Kitakyushu 802-0001, Japan
TEL. 81-93-511-4741 FAX. 81-93-511-4580



Design, development, and manufacture of level measuring sensors

Agent