

LASER TYPE LEVEL INDICATOR **LASER SERIES**



**NON-CONTACTING TYPE OF LONG SPAN / PINPOINT
MEASUREMENT. BEST SUITABLE FOR PLACES WHERE IT IS
HIGHLY DIFFICULT OR DANGEROUS TO MEASURE!!**

Highly powered laser generates the higher rate of its response and enables pinpoint measurement of a long span up to 30m.



Sensor



Controller

LASER RANG-L



LONGRANG TYPE

Measuring range up to 30m at the maximum. Besides sensor/control one-unit or separate type meeting the installation site in the plant, flange-fix type, platform-fix type & others for surveillance camera can be designed and manufactured in accordance with each application. It is best suitable for non-contacting measurement at the places where it is highly difficult or dangerous to measure with conventional level meters.

FEATURES

- Non-contacting measurement up to 30m at the maximum can be possible.
- It is possible to measure by pinpoint at the places where there are many obstructions.
- You can visually observe the measuring spot as it is dotted in red.
- It is possible to measure from outside through an observation window or hole on a tank and so on if any.
- Various optional products to meet customers' needs.

APPLICATIONS

- Collision avoidance of an overhead traveling crane.
- To measure the stuff thickness of extruder/winder
- To measure level of garbage, ash and others in a waste disposal plant.
- Level measurement at crushing and grinding plant.
- To measure food, processed stuffs and others in a non-contacting

STANDARD SPECIFICATION

- TYPE :** LASER RANG-L
RANGE : 0.2~30m (varied by conditions)
OUTPUT : DC4~20mA Load Resistance below 300Ω
TEMPERATURE : -10~+45°C (No freezing, (No freezing, no condensation)
HOUSING RATING : IP54 equivalent
HOUSING MATERIAL : Flange : 304SS Sensor : 304SS Controller: Aluminum mold
LASER SPECIFICATION : Class 2 Semiconductor laser radiation, 620-690nm
POWER VOLTAGE : 0.95mWmax
POWER CONSUMPTION : 90~240VAC or 24VDC 0.34A (at 100VAC)

OUTLINE DRAWING

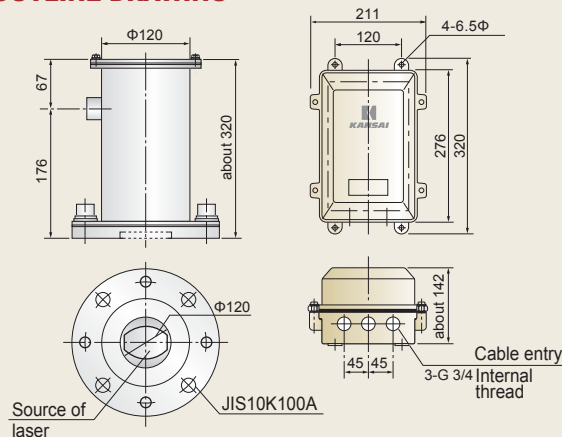

CONFIGURATION DIAGRAM

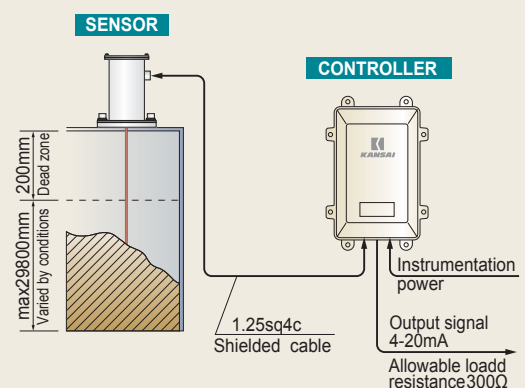

Being compact and light body, it can closely measure a short span up to 10m. No conditioning is needed.

Class
2

LASER RANG-S



SHORTRANG TYPE

It is a level meter developed in the pursuit of compact, light and budget-priced model for the purpose of measuring a short span up to 10m. It can be fixed on by a small-bore (G2 thread). It is possible to measure from outside just as Laser Rang-L. It is best suitable for non-contacting measurement at the places where it is highly difficult or dangerous to measure with conventional level meters.

FEATURES

- Non-contacting measurement up to 10m at the maximum can be possible.
- Besides the advantages of Laser Rang-L, it is compact, light and budget-priced.
- It is possible to measure from outside through an observation window or hole on a tank and so on if any.
- The measuring range is adjusted before shipment, and no other adjustment is needed after wiring/installation.

APPLICATIONS

- To measure the distance to the face of chromatic object in a tank.
- To measure level in an open vessel with the unit fixed on ceiling.
- Level measurement at crushing and grinding plant.
- To measure food, processed stuffs and others in a non-contacting manner.

STANDARD SPECIFICATION

- TYPE :** LASER RANG-S
RANGE : 0.2~10m (varied by conditions)
OUTPUT : DC4~20mA Load Resistance below 300Ω
CABLE : with cable in 5m
TEMPERATURE : -10~+45°C (No freezing, no condensation)
HOUSING RATING : IP43 equivalent
HOUSING MATERIAL : PVC
LASER SPECIFICATION : Class 2 Semiconductor laser radiation, 620-690nm 0.95mWmax
POWER VOLTAGE : 24VDC ±10%
POWER CONSUMPTION : 150mA

OUTLINE DRAWING

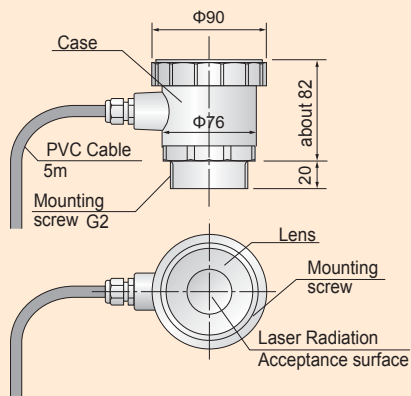

CONFIGURATION DIAGRAM

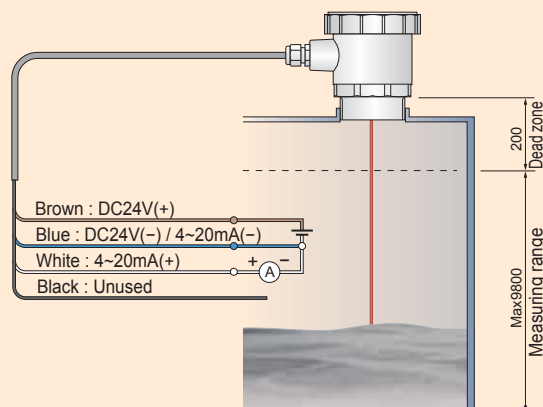

Sensing by pin spot whether the laser is broken or not.
A distant object by 20m can be detected by millimeter.



TK-LASER-TN/RN

It is a level switch utilizing laser as a light source, consisting of two facing units.

The use of the strong laser power by 3A makes it possible to reliably detect in transmitting into such an environment as vapor and dust, whose detection was not easy with conventional photoelectric switches.

Class 3A

FEATURES

- A pair of facing units can be separated by 20m at the maximum.
- Built-in interlock circuit.
- Built-in delay circuit preventing any glitch.
- Built-in alarm lamp while

APPLICATIONS

- Control the filter-cloth position of sludge processor.
- Detecting falling objects from a conveyor-belt.
- Control level of crushed papers.

STANDARD SPECIFICATION

TYPE : TK-LASER-TN/RN

MEASURING RANGE : Distance of two facing units within 20m

OUTPUT : 1SPDT 250VAC 10A
ON Delay 0.1~10sec variable

TEMPERATURE : -10~+50°C
(No freezing, no condensation)

HOUSING RATING : IP54 equivalent

HOUSING MATERIAL : Case : ADC
Flange : AC
Boss, Lightproof pipe: SUS304

LASER : Class 3A Semiconductor laser

SPECIFICATION : radiation, below 635nm5mW

POWER VOLTAGE : 105 / 210VAC ±10%

POWER CONSUMPTION : TN: 20VA RN: 10VA

OUTLINE DRAWING

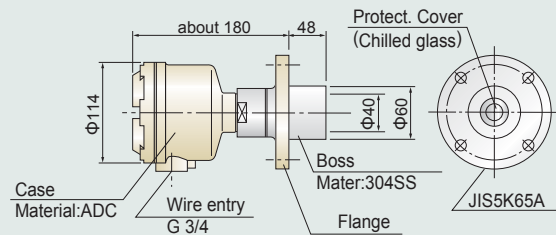

CONFIGURATION DIAGRAM

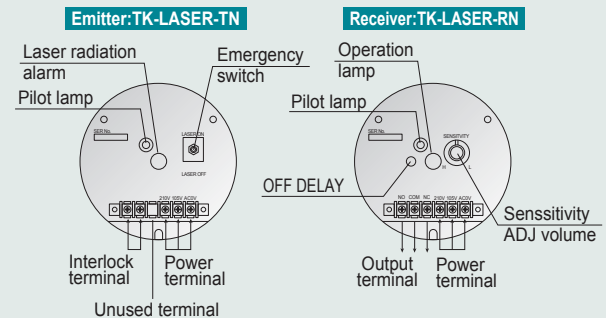

*Make sure of the notes on the right in order to safely use LASER RANG -L LASER RANG -S & TK- LASER TN/RN.



- The power density of laser beam is high and may pose a danger to public health. Take adequate safety measures.
- Never peer into the lens. Taking a long look at laser beam may seriously harm your

CLASS OF VISIBLE-LIGHT LASER (400-700nm)

	Class 1	Class 2	Class3A	Class3B
Opticer	below 6.8É W	below 1mW	below 5mW	below 0.5W
Danger	Intrinsically safe in design	Low output laser-safe by turning eyes away	Optical observation into the beam is dangerous.	Visual observation into the beam is dangerous.
Class label	Required	"Caution" label	"Danger" label	"Danger" label

Line of business

- Rotary Paddle Type Level Switch
- Vibration Type Level Switch
- Swing Type Level Switch
- Acoustic Level Switch
- Capacitance Type Level Switch
- Capacitive Proximity Sensor
- Capacitance Type Level Indicator
- Diaphragm Type Level Switch
- Tiit Switch
- Leak Type Level Switch
- Microwave Switch
- Sounding Bob Type Level Indicator
- Flow Switch
- Conductance Type Level Switch
- Float Switch
- Float Type Level Indicator
- Ultrasonic Type Level Indicator
- Equipments For Conveyor Lines
- Dust Monitor System
- Zirconia Oxygen Analyzer
- Laser Type Level Indicator
- RADAR Type Level Indicator
- On-line Sensors for Accurate Liquid Analysis
- Ultrasonic Flow meter

*Please be sure to read USER'S GUIDE, Installation & Operation Instructions before using the instrument.

*The specifications herein may be subject to change without advance notice.

Nuclear Power Generation to Rice Milling
All-round Manufacturer of Level Controllers for Powder, Granules and Liquid

KANSAI Automation Co., Ltd.

Headquarters :
2-14, Togano-cho, Kita-ku, Osaka 530-0056, Japan
TEL. 81-6-6312-2071 FAX. 81-6-6314-0848
e-mail: info@kansai-automation.co.jp

<http://www.kansai-automation.co.jp>

Tokyo Branch : 1-29-6, Hamamatsu-cho, Minato-ku, Tokyo 105-0013, Japan
TEL. 81-3-5777-6931 FAX. 81-3-5777-6933

Nagoya Office : 3-31-27, Uchiyama, Chigusa-ku, Nagoya 464-0075, Japan
TEL. 81-52-741-2432 FAX. 81-52-741-1588

Kyushu Office : 1-2-39, Asano, Kokura Kita-ku, Kitakyushu 802-0001, Japan
TEL. 81-93-511-4741 FAX. 81-93-511-4580



Design, development, and manufacture of level measuring sensors

Agent