

SOUNDING LEVEL INDICATOR

KSL-T8/GT

Highly Intelligent and Robust

Reliably Catching Level for Powder/Granules/Blocks and
Transmitting Signals from the Remote Area



Featuring of being Highly Intelligent as well as Robust

This is the instrument metering the level of powder, granules and blocks stored in a tank, a silo and so on and transmitting the signals from the remote area. The accurate stock management ensures to help smoothly achieve the production goal and contributes to the improved quality. There being no need of measuring on the site because the level instructions are directed from the remote, you can expect improvement in terms of the working and safety environment

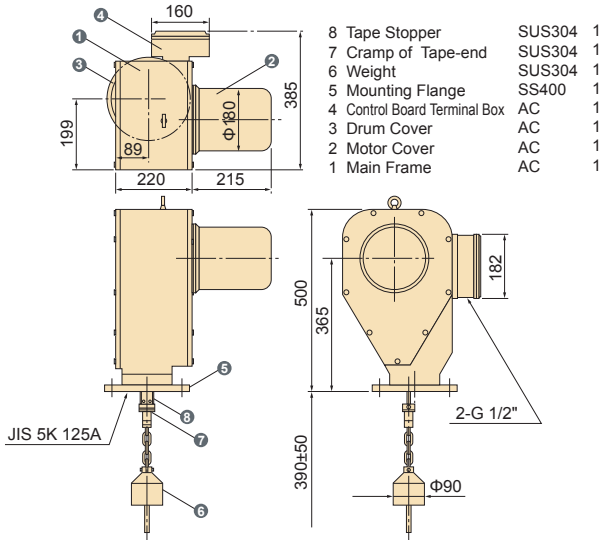

SOUNDING LEVEL METER (CPU) **KSL-T8**

Standard Specifications (CPU)

- Power Voltage :** 100VAC or 200VAC, Single-phase 50/60Hz
- Measuring Range :** Standard 20m, Max. 40m (Option)
- Elevating Speed :** 9.3m/min (50Hz), 11.0m/min (60Hz)
- Measure :** SUS304 tape
- Motor :** Single-phase 100VAC40W
: Single-phase 200VAC40W
- Elect. Capacity :** Max. 150VA
- Output Signal :** Current Signal DC4~20mA (Indicate remains)
DC20~4mA (Indicate vacated portion)
*May set up either way.
- Pulse Contact Signal** 1 pulse/1cm
(No voltage) 1 pulse/10cm
*May set up either way. Contact capacity is 250VAC5A.
- Measuring Method :** Pulse Counting
- Measuring Unit :** 1 pulse/10cm or 1 pulse/1cm
- Measuring Accuracy :** ±10cm/±1cm
- Tolerable Temperature :** -10°C~50°C around or inside tank
(No condensation)
- Built-in Timer :** Measuring standby time can be adjusted by set-up.
- Contact Output :** Reset Contact/Closed when the remote display counter is reset
- Trouble Alarm Contact/ Flickers** when the measuring tape is cut off.
The contact (1a) is closed when the weight is buried.
- Detection Switch :** Switches for Powder Surface, Winding-up and Burial, are all non-contact switches.
- Material :** Main Frame of Aluminum, Weight of SUS304, Tape of SUS304
- Mounting Dimensions :** JIS 5K5B
- Protection Structure :** IP66 or equivalent
- Painted Color :** Metallic Silver, Weight 45kg

Circuit Board Layout/ Interconnecting Diagram

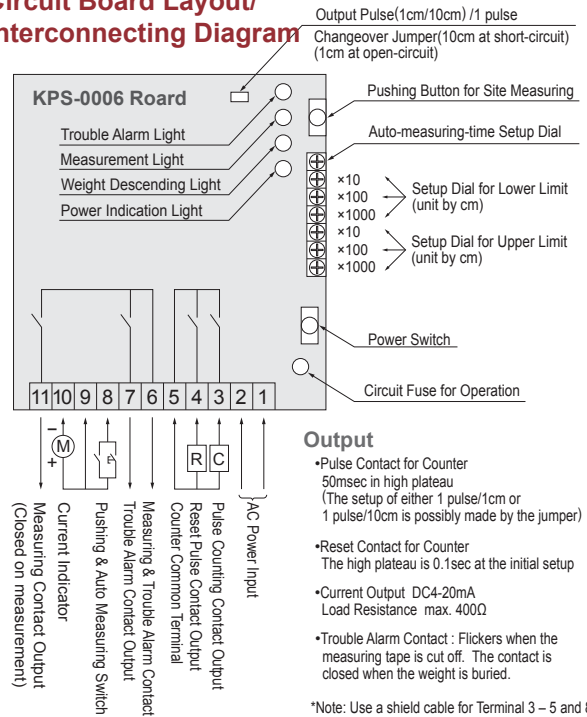

Equipment Configuration/CPU Model

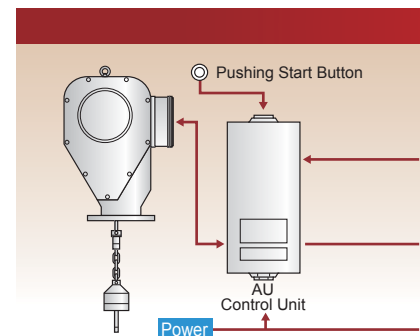
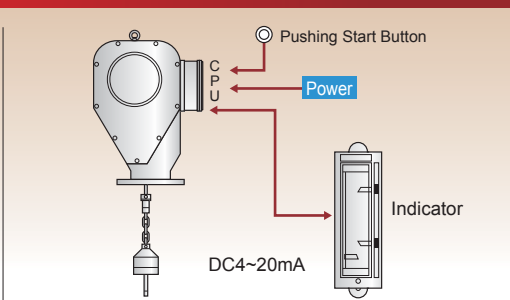
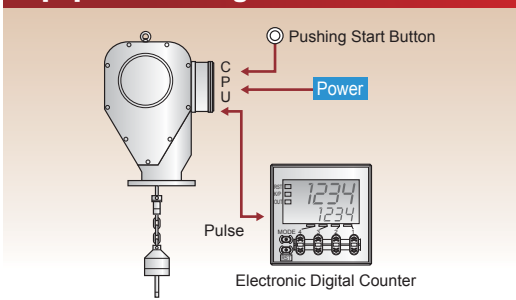

Features

- ① Its measurement being simple mechanical processes, it may not easily be affected by the measuring substance or surrounding influences.
- ② The built-in CPU makes it possible to do pulse output or analogue output direct from the sensing unit.
- ③ This comes equipped with Trouble Alarm Contact.
- ④ This comes with a built-in CPU self-diagnostic mode and other various check modes.
- ⑤ Auto-measuring timer being built in the sensing unit, you need not to secure exterior space for the timer.

Principle of Operation

When you push a measuring switch, the motor activates and the weight starts to descend in a tank. In this occasion, the sensing unit transmits pulse signals. It outputs the current signals of DC4 – 20mA when the weight reaches the powder level. The motor stops as soon as the weight reaches the powder level and then starts to reverse. When it fully rolls up, the motor stops and the measurement is completed. The output of DC4 – 20mA will be kept until the next measurement.

SOUNDING LEVEL METER (AU) **KSL-T8**

■ Standard Specifications(AU)

- Power Voltage** : 100VAC or 200VAC, Single-phase 50/60Hz
- Measuring Range** : 0 – 20m, Max. 40m (Option)
- Elevating Speed** : 11.0m/min(60Hz), 9.3m/min(50Hz)
- Measure** : SUS304 tape
- Motor** : Single-phase 100VAC40W
Single-phase 200VAC/40W
- Elect. Capacity** : 150VA
- Measuring Method** : Pulse Counting
- Measuring Unit** : 1 pulse/10cm
- Measuring Accuracy** : ±10cm
- Tolerable Temperature** : -10°C~+50°C around or inside tank
(No condensation)
- Mounting Dimensions** : JIS5K5B
- Weight** : SUS304
- Weight** : 45kg
- Painted Color** : Metallic Silver
- Protection Structure** : IP66 or equivalent
- Other functions** : Trouble Alarm/Alarm of Tape-cut or Weight-buried

Equipment Configuration/AU

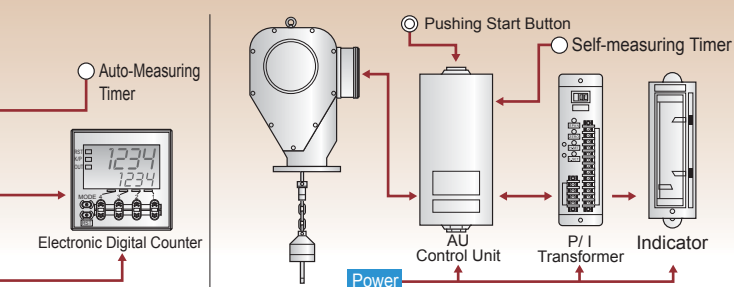

SOUNDING LEVEL METER (AU) **KSL-GT**

KSL-GT
Withstand Pressure
/ Explosion-proof
Exd II BT4LIC14006

Certified by Labor Ministry Industrial Safety
Laboratory on Explosion-proof Standards
For Explosive Environment

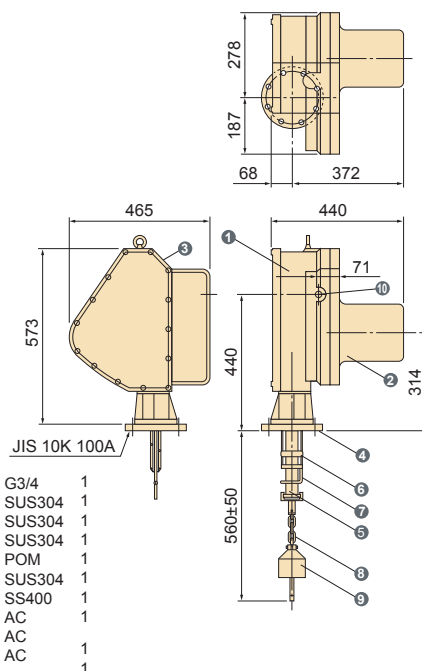

Features

It can effectively function in the explosive gas environments such as chemical/medical factories as well as power station. In succession to features of Tape Type Sounding Level Meter, it can activate reliably regardless of particulates, temperature changes, and electric fluctuation of measuring substances.

Principle of Operation

About one second after the starting signal is input, the weight-attached tape descends in a tank, and the unit transmits pulses at a regular interval. As soon as the weight reaches the measuring substance, the balance between the weight and other balance weight attached to the motor gets imbalanced, which has the motor tilted clockwise and activates the powder level switch; it starts winding the measuring tape up and then the weight returns up to the original position until the motor makes a stop to standby.

■ Standard Specifications(AU)

- Power Voltage** : 100VAC or 200VAC, Single-phase 50/60Hz
- Measuring Range** : 0 – 20m, Max. 30m (Option)
- Elevating Speed** : 11.0m/min (60Hz) / 9.3m/min (50Hz)
- Measure** : SUS304 tape
- Motor** : Single-phase 100VAC40W, Class E Insulating
33% ED twice/hour (condenser 15μF)
Single-phase AC200VAC 40W Class E Insulating
33% ED twice/hour (condenser 3.5μF)
- Elect. Capacity** : 150VA
- Measuring Method** : Pulse Counting
- Measuring Unit** : 1 pulse/10cm
- Measuring Accuracy** : ±10cm
- Tolerable Temperature** : -10°C~+40°C around or inside tank
(No condensation)
- Mounting Dimensions** : JIS10K4B
- Weight** : SUS304
- Weight** : 75kg
- Painted Color** : Metallic Silver
- Protection Structure** : Indoors (Use raintight cover for outdoors.)
Option (IP64 or equivalent)
- Other functions** : Trouble Alarm/Alarm of Tape-cut or Weight-buried

Equipment Configuration AU/CPU Model

Indicator/NRE-152K(Contact both at Upper & Lower)

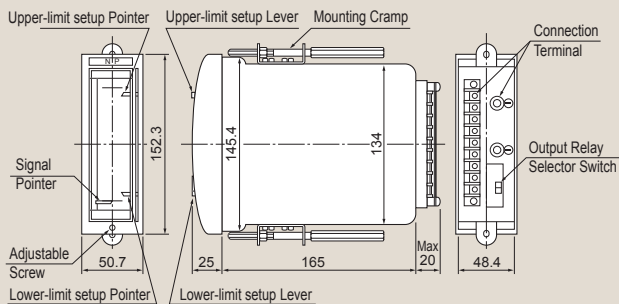

Equipment Configuration AU Model

Control Unit (KSLAU)

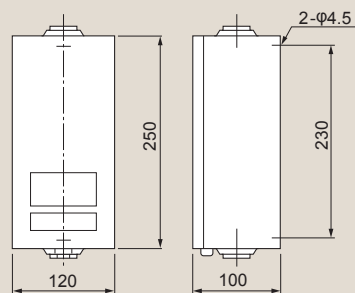

Electronic Digital Counter / H7CX-A114

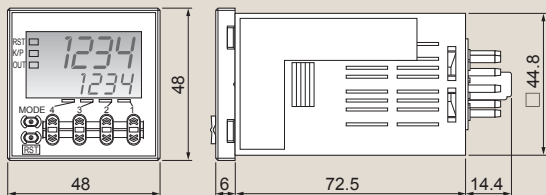

P/I Transformer(PSC)(Output at both Upper & Lower Contact)

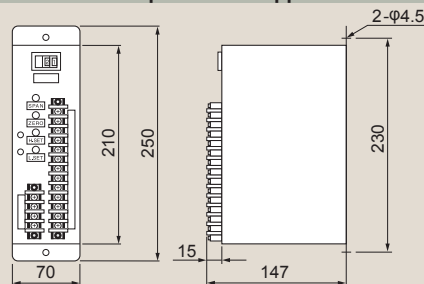

Please advise the following information for your inquiries and ordering.

- | | | |
|--|---|----------------|
| 1. Name of Measuring Substance | [|] |
| 2. Specific Gravity of the Substance | [|] |
| 3. Granularity of the Substance | [|] |
| 4. Moisture of the Substance | [|] |
| 5. Temperature in a Tank | [|] |
| 6. Pressure in a Tank | [|] |
| 7. Ambient Temperature | [|] |
| 8. Power Voltage | [|] |
| 9. Control Unit | [| Need · No need |
| 10. P/I Transformer | [| Need · No need |
| 11. Mounted Equipment (Counter, Indicator) | [| Need · No need |

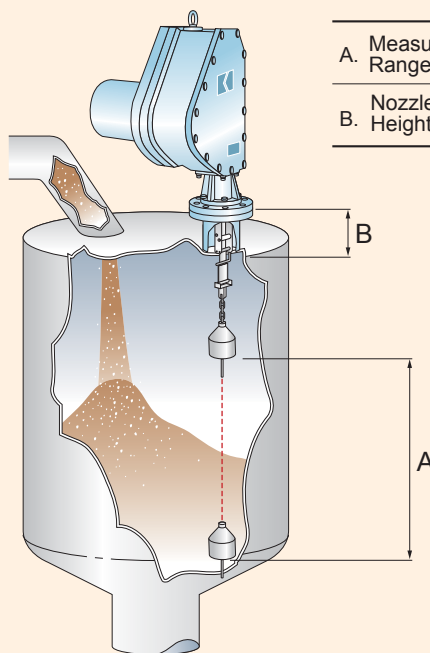

- | | | |
|--------------------|---|---|
| A. Measuring Range | [|] |
| B. Nozzle Height | [|] |

Line of business

- Rotary Paddle Type Level Switch
- Vibration Type Level Switch
- Swing Type Level Switch
- Acoustic Level Switch
- Capacitance Type Level Switch
- Capacitive Proximity Sensor
- Capacitance Type Level Indicator
- Diaphragm Type Level Switch
- Tilt Switch
- Leak Type Level Switch
- Microwave Switch
- Sounding Bob Type Level Indicator
- Flow Switch
- Conductance Type Level Switch
- Float Switch
- Float Type Level Indicator
- Ultrasonic Type Level Indicator
- Equipments For Conveyor Lines
- Dust Monitor System
- Zirconia Oxygen Analyzer
- Laser Type Level Indicator
- RADAR Type Level Indicator
- On-line Sensors for Accurate Liquid Analysis
- Ultrasonic Flow meter

*Please be sure to read USER'S GUIDE, Installation & Operation Instructions before using the instrument.

*The specifications herein may be subject to change without advance notice.

Nuclear Power Generation to Rice Milling
All-round Manufacturer of Level Controllers for Powder, Granules and Liquid

KANSAI Automation Co., Ltd.

Headquarters :
2-14, Togano-cho, Kita-ku, Osaka 530-0056, Japan
TEL. 81-6-6312-2071 FAX. 81-6-6314-0848
e-mail: info@kansai-automation.co.jp

<http://www.kansai-automation.co.jp>

Tokyo Branch : 1-29-6, Hamamatsu-cho, Minato-ku, Tokyo 105-0013, Japan
TEL. 81-3-5777-6931 FAX. 81-3-5777-6933

Nagoya Office : 3-31-27, Uchiyama, Chigusa-ku, Nagoya 464-0075, Japan
TEL. 81-52-741-2432 FAX. 81-52-741-1588

Kyushu Office : 1-2-39, Asano, Kokura Kita-ku, Kitakyushu 802-0001, Japan
TEL. 81-93-511-4741 FAX. 81-93-511-4580



Design, development, and manufacture of level measuring sensors

Agent