

CAPACITANCE TYPE LEVEL INDICATOR

Model **KLI/KLT/KLG** SERIES



**NO MOVING PART,
EASY TO HANDLE!!**

Wide measuring span

Cement or the like



Unaffected by dust on pneumatic conveyor

Cement or the like



Unaffected by fouling

Flour or the like



Interfacial detection of two liquids

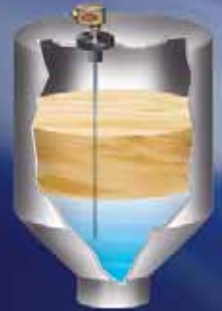

KLI/KLT/KLG SERIES

CAPACITANCE TYPE LEVEL INDICATOR

THERE BEING NO MOVING PART, IT RELIABLY OPERATES FOR A LONG PERIOD OF TIME AND ITS MAINTENANCE IS EASY. BEST SELLING LINE IN CONTINUOUS MEASUREMENT

FEATURES

- Reliable detection even when objects are being fed.
- It can be applied to anything including powder, granules and liquid.
- Not affected by dust, it can accurately indicate.
- It is possible to select one of the most suitable sensors out of a wide range of products, depending upon the applicable conditions. (high temperature, high pressure, strong acid/ alkali, conductivity, insulation property and others)
- Safely measure a wide span with electrodes designed to be strong enough.
- The intrinsically safe explosion-proof model is also available for use at an explosive area.

Accurate detection of minimal capacitance

Adhesives, Lard (Food oil), Liquefied gas & others

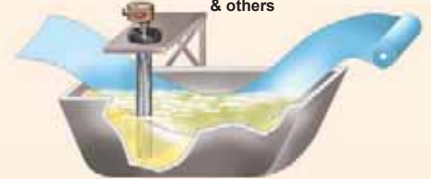

Operating Principle

When an electrode is set in a tank so as to be coaxial with its wall as shown below, there forms a capacitance C_x between the tank and the electrode. By offsetting the stray capacitance of C_o , when the tank is empty, with a high frequency impedance bridge, it is possible to obtain ΔC , namely the output electric signal which is proportional to the height (level) l_1 of the material to be measured.

$$C_x = C_o + \Delta C$$

$$\Delta C = \frac{K(\epsilon_2 - \epsilon_1) l_1}{\log_{10}(R/r)}$$

(Increment of capacitance when the tank is filled with materials to be measured.)
 (C_o : Capacitance when the tank is empty, K = Constant)

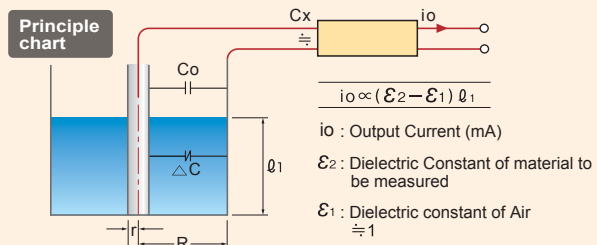



model **KLI**

Agitating vessel

Liquid, dirt or the like



Unaffected by static electricity

Resin pellet



Electrode · Amplifier Remote Type

(Outdoor wall mount)

- Length of Exclusive Cable: Max.50m (Sensitivity Class1 =Max.25m)
- 24VDC model can be available
- Electrostatic protective model can be manufactured.

model **KLG**

Intrinsically safe explosion-proof model (I)2G4 RIIS No.44622



- Attached safety barrier
- Exclusive cable : Max.25m

■ APPLICATIONS

Molten resin

Organic solvent

Flour

Food oil

Heavy oil

Sludge

Sulphuric acid

Caustic soda

Industrial water

Fruit juice

Sea water

Waste water

Cement

Grain

Resin pellet

Calcium carbonate

Powdered coal

Metal powder

model **KLT**

Electrode · Amplifier Built-in Type

- No exclusive cable is required.
- 24VDC model can be available.

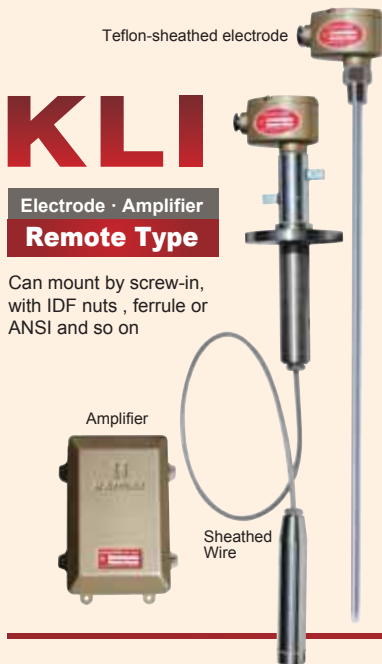

KLI

Electrode · Amplifier
Remote Type

Can mount by screw-in, with IDF nuts, ferrule or ANSI and so on

ELECTRODE

- Permissibly Distributed Capacitance : 0~400pF (Depending on shape)
- Operating Temperature : -25~+80°C (Standard Specification)
-200~+500°C (Option)
- Maximum Pressure : 980KPa (10kgf/cm²) (Standard)
- Housing : IP-66
- Color : Hammer-net gold

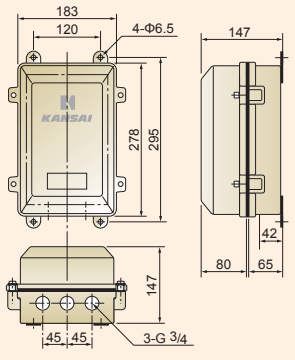
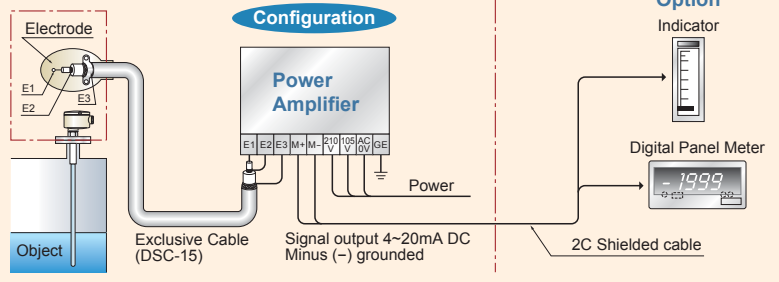

POWER · AMPLIFIER (Outdoor wall mounting)

- Input Power Source : 105/210VAC ±15% 50/60Hz (24VDC OK)
 - Power Consumption : 4VA
 - Output Signal : 4~20mA DC, (500Ω Max) (-) grounded
 - Measuring Sensitivity : 10pF, 30pF, 300pF, 3000pF (F-S)
 - Accuracy : (Amplifier) 1%
 - Weight : 6.5Kg (Outdoor use)
 - Box Type : Outdoor Wall mounting or Panel built-in
 - Length of Exclusive Cable : Max. 50m (Sensitivity Class1=Max.25m)
 - Operating Temperature : -20~+70°C
 - Housing : IP-55 equivalent
 - Color : Hammer-net gold
- *Compact amplifier (panel mounting) is optionally available.

OUTLINE DRAWING

KLI-1 □ 3 Special B31-Z-SP-65

Mounting : JPI300#3B
Temperature : -20~+80°C
Pressure : 980KPa
Length of L : Max 4m

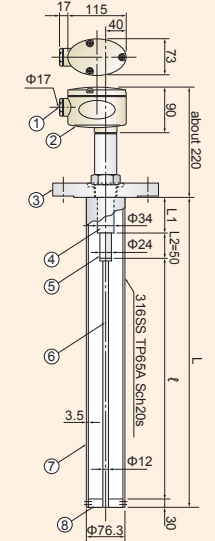

- | | | |
|---|---------------------|---------|
| 1 | Cable Gland | C3604 |
| 2 | Housing Flange | AC4B |
| 3 | Earth electrode | 316SS |
| 4 | Insulator | 316SS |
| 5 | Main electrode | Ceramic |
| 6 | Auxiliary electrode | 316SS |
| 7 | Insulator supporter | 316SS |
| 8 | | Teflon |

KLI-2 □ 3 K·P·2·17

Mounting : JIS10K50A
Temperature : -20~+80°C
Pressure : 980KPa
Length of L : Max 4m

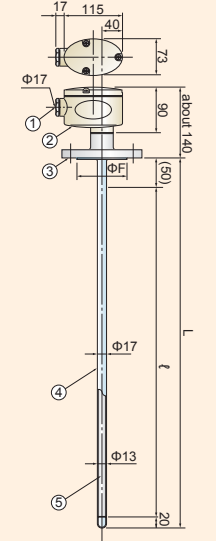

- | | | |
|---|----------------|--------|
| 1 | Cable gland | C3604 |
| 2 | Housing | AC4B |
| 3 | Flanage | 304SS |
| 4 | Sheath | Teflon |
| 5 | Main electrode | 304SS |

KLI-4 □ 3 K·W·10P· (G)

Mounting : JIS10K65A
Temperature : -20~+80°C
Pressure : 980KPa
Length of L : Max 15mm

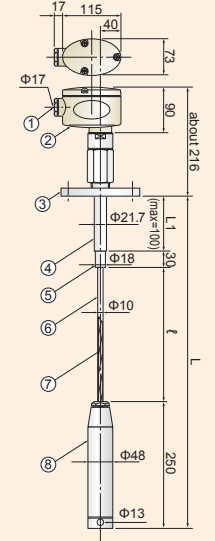

- | | | |
|---|---------------------|------------|
| 1 | Cable gland | C3604 |
| 2 | Housing | AC4B |
| 3 | Flanage | 304SS |
| 4 | Earth electrode | 304SS |
| 5 | Insulator | Polyacetal |
| 6 | Sheathed | Teflon |
| 7 | Main electrode wire | 304SS |
| 8 | Weight | 304SS |

KLI-4 □ 3 K·W·15P·3

Mounting : JIS10K65A
Temperature : -20~+80°C
Pressure : 980KPa
Length of L : Max 30m

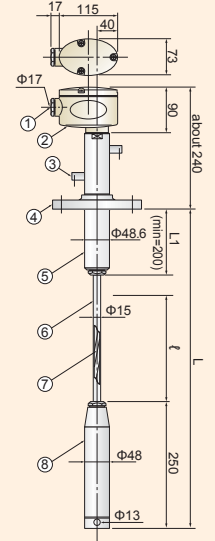

- | | | |
|---|---------------------|--------|
| 1 | Cable gland | C3604 |
| 2 | Housing | AC4B |
| 3 | Vent | SS400 |
| 4 | Flanage | 304SS |
| 5 | Earth electrode | 304SS |
| 6 | Sheath | Teflon |
| 7 | Main electrode wire | 304SS |
| 8 | Weight | 304SS |

KLI-6 □ 3 Pyrex K·P·1·20·SP (50A)

Mounting : JIS10K65A
Temperature : -20~+200°C
Pressure : 1960KPa
Length of L : Max 1m

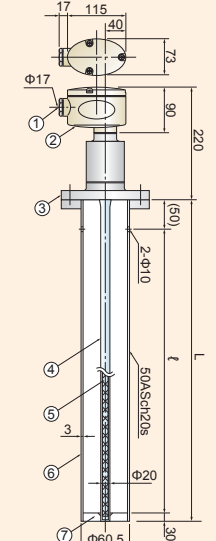

- | | | |
|---|--------------------------|-------|
| 1 | Cable gland | C3604 |
| 2 | Housing | AC4B |
| 3 | Flanage | 304SS |
| 4 | Sheath | Pyrex |
| 5 | Main electrode | 304SS |
| 6 | Auxiliary electrode | 304SS |
| 7 | Main electrode supporter | 304SS |

KLT

Electrode · Amplifier
Built-in Type

Can mount by screw-in,
with IDF nuts, ferrule or
ANSI and so on

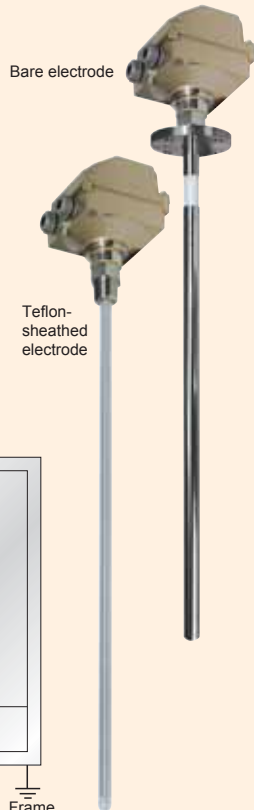

STANDARD SPECIFICATION

- Input Power Source : 105 /210VAC ±15% 50/60Hz (24VDC OK)
- Power Consumption : 4VA
- Output Signal : 4~20mA DC, (500Ω Max) Minus (-) grounded
- Measuring Sensitivity : 10pF, 30pF, 300pF, 3000pF (F. S)
- Accuracy : 1%
- Permissibly Distributed Capacitance : 0~400pF (Depending on shape)
- Operating temperature : -25~+80°C (Standard)
-200~+500°C (Special)
- Maximum Pressure : 980KPa (10kgf /cm²) (Standard Specification)
- Housing : IP-66 equivalent
- Color : Hammer-net gold

WIRING DIAGRAM

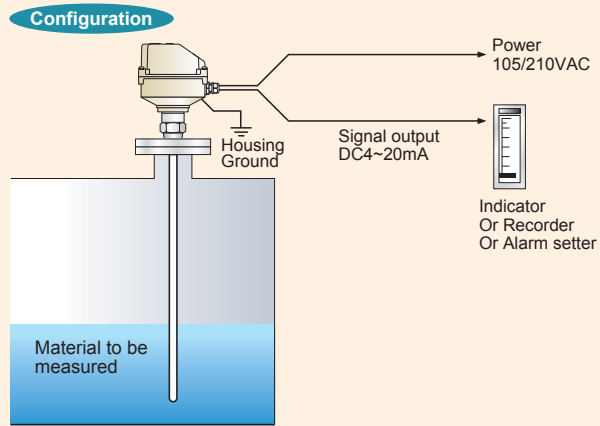
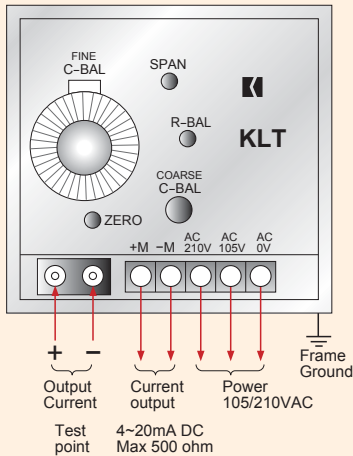

OUTLINE DRAWING

KLT-2 T·P1·17·IN2S

Mounting : IDF2s
Temperature : -20~+50°C
Pressure : 980KPa
Length of L : Max 4m

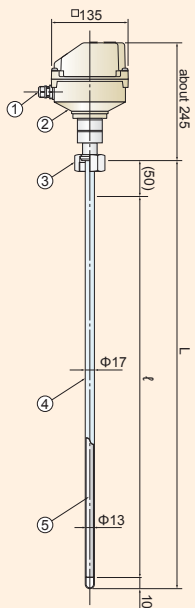

- | | |
|------------------|------------|
| 1 Cable gland | Polyacetal |
| 2 Housing | ADC |
| 3 IDF union nut | 304SS |
| 4 Sheath | Teflon |
| 5 Main electrode | 304SS |

KLT-2 □ 0 T·P1·17·IF2S

Mounting : Ferrule
Temperature : -20~+50°C
Pressure : 980KPa
Length of L : Max 4m

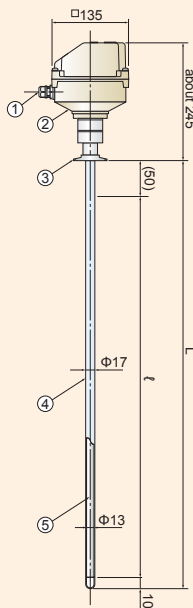

- | | |
|------------------|------------|
| 1 Cable gland | Polyacetal |
| 2 Housing | ADC |
| 3 Ferrule | 304SS |
| 4 Sheath | Teflon |
| 5 Main electrode | 304SS |

KLT-3 □ 0-H Special T·W8·B3·H3

Mounting : JIS10K50A
Temperature : -20~+400°C
Pressure : 980KPa
Length of L : Max15m

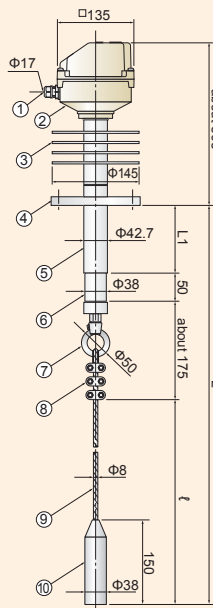

- | | |
|-------------------|------------|
| 1 Cable gland | Polyacetal |
| 2 Housing | ADC |
| 3 Fin | AC |
| 4 Flange | 304SS |
| 5 Earth electrode | 304SS |
| 6 Insulator | Ceramic |
| 7 Eyenut | 304SS |
| 8 Wire clip | 304SS |
| 9 Main electrode | 304SS |
| 10 Weight | 304SS |

KLT-4 □ 0 T·W·10P·L

Mounting : JIS10K50A
Temperature : -20~+50°C
Pressure : 980KPa
Length of L : Max15m

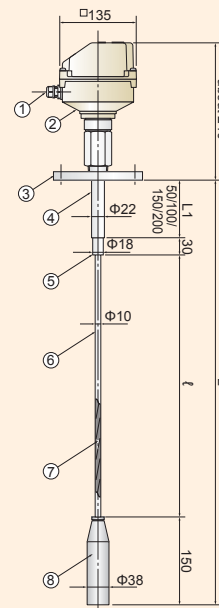

- | | |
|-----------------------|------------|
| 1 Cable gland | Polyacetal |
| 2 Housing | ADC |
| 3 Flange | 304SS |
| 4 Earth electrode | 304SS |
| 5 Insulator | Polyacetal |
| 6 Sheath | Teflon |
| 7 Main electrode wire | 304SS |
| 8 Weight | 304SS |

KLG

Intrinsically safe explosion-proof model (i)2G4 RIIS No.44622

FOR HAZARDOUS GAS ENVIRONMENT

Explosion-proof available
Certified by Industry Safety-Technology Association, Labor Ministry.

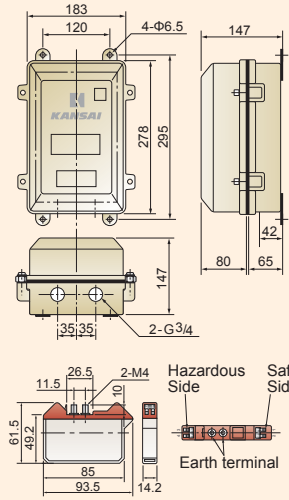

Can safely be used at any explosive environment.

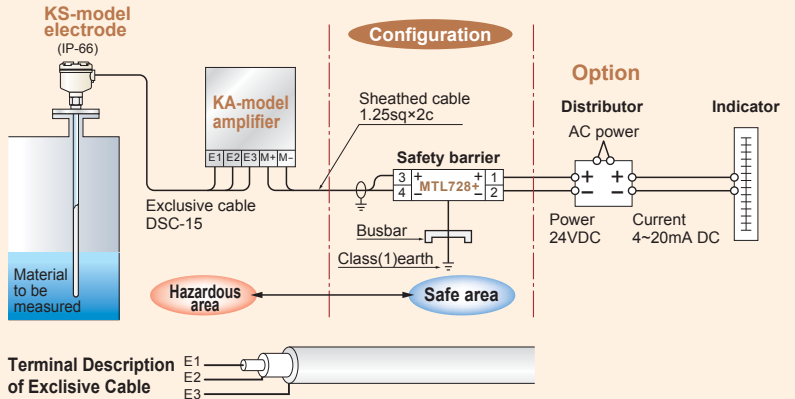

POWER

- Power Consumption : 4 VA
- Output Signal : 4~20mA DC (100Ω Max)
- Measuring Sensitivity : 130pF, 300pF, 3000pF
- Accuracy : (Amplifier) 1%
- Weight : 6.0 kg
- Housing : Outdoor Wall mounting
- Length of Exclusive Cable : Max.25 m
- Housing : IP-66
- Painting Color : Hammer-net gold

STANDARD SPECIFICATION (Option)

- Distributor: 100 /110VAC or 200 /220V
- Allowable load resistance 600Ω Max
- (Using Model7552 made by Tsuruga Electric Corp.)

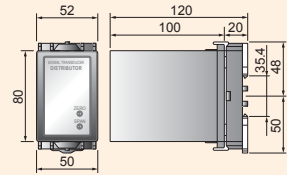

OUTLINE DRAWING

KLG-2□3 G·P1·17·SP(40A)

Mounting : JIS10K50A
Temperature : -20~+80°C
Pressure : 980KPa
Length of L : Max 4m

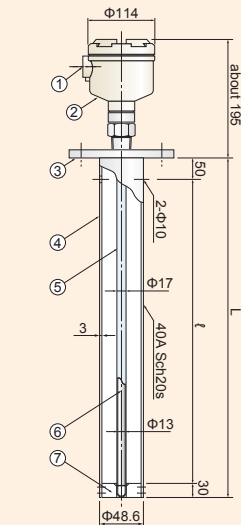

- | | |
|----------------------------|--------|
| 1 Cable gland | G 3/4 |
| 2 Housing | ADC |
| 3 Flanage | 304SS |
| 4 Auxiliary electrode | 304SS |
| 5 Sheath | Teflon |
| 6 Main electrode | 304SS |
| 7 Main electrode supporter | Teflon |

KLG-2□3 G·P1·17

Mounting : R1
Temperature : -20~+80°C
Pressure : 980KPa
Length of L : Max 4m

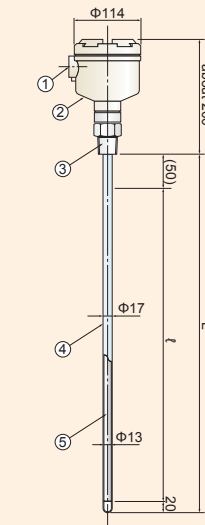

- | | |
|------------------|--------|
| 1 Cable gland | G 3/4 |
| 2 Housing | ADC |
| 3 Screw | 304SS |
| 4 Sheath | Teflon |
| 5 Main electrode | 304SS |

KLG-2□3 G·P1·17·IF·1S

Mounting : IDF ferrule 1S
Temperature : -20~+80°C
Pressure : 980KPa
Length of L : Max 4m

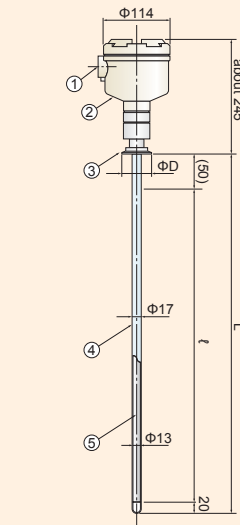

- | | |
|-------------------|--------|
| 1 Cable gland | G 3/4 |
| 2 Housing | ADC |
| 3 Ferrule | 304SS |
| 4 Sheath | Teflon |
| 5 Main electrode4 | 304SS |

KLG-4□3 G·W·10P·L

Mounting : JIS10K50A
Temperature : -20~+80°C
Pressure : 980KPa
Length of L : Max 15m

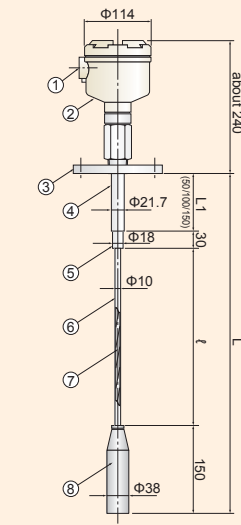

- | | |
|-----------------------|------------|
| 1 Cable gland | G 3/4 |
| 2 Housing | ADC |
| 3 Flanage | SUS304 |
| 4 Earth electrode | SUS304 |
| 5 Insulator | Polyacetal |
| 6 Sheath | Teflon |
| 7 Main electrode wire | SUS304 |
| 8 Weight | SUS304 |

OPTIONAL UNITS

DIGITAL METER RELAY MR-B51D5



Size: 1/8DIN W48×H96mm
Power: 85~265VAC / 95~370VDC
(Common power source for AC/DC)

Consumption: 5W
Indication: Digital (5 digit LED display)
Bargraph (51 segment LED)
Output contact: 2SPDT (C contact)
2SPST (A contact), can be added
Remarks: LED with brightness control
Output contact can be expanded up to 6 at the maximum.
(A contact only)

BARGRAPH METER M-B101



Size: 9/64DIN W36×H144mm
Power: 85~265VAC / 95~370VDC
(Common power source for AC/DC)

Consumption: 5W
Indication: Bargraph (101 segment LED)
Output contact: nil
Remarks: LED with brightness control

BARGRAPH METER RELAY MR-B101D4

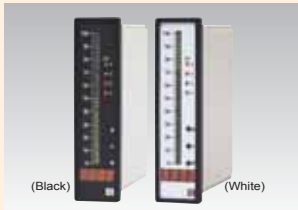

Size: 9/64DIN W38×H144mm
Power: 85~265VAC / 95~370VDC
(Common power source for AC/DC)

Consumption: 5W
Indication: Digital (4 digit LED display)
Bargraph (101 segment LED)
Output contact: 2SPDT (C contact)
2SPST (A contact), can be added
Remarks: LED with brightness control
Output contact can be expanded up to 6 point at the maximum.
(A contact only)

TENSION TEST Osaka Prefectural Industry Technology Research, 2/24/84

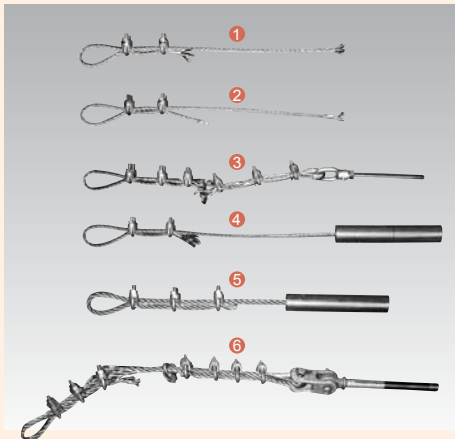

NAME OF PARTS FOR TENSION TEST

- ① $\Phi 8$ wire rope at lead brazing
- ② $\Phi 8$ wire rope/ prevent falling
- ③ $\Phi 8$ wire rope/ eyenut
- ④ $\Phi 8$ wire rope/ bob base
- ⑤ $\Phi 12$ wire rope/ bob base
- ⑥ $\Phi 12$ wire rope/ eyebolt



③ Description of Deformed Part
The eyenut ring ovalizes but does not crack. No exception is noted on the screw-thread part of stainless steel bar.

③ $\Phi 8$ Wire
Eyenut Method
An eyenut and a heart thimble deform but withstand any breakage. The withstanding weight is 4.345 tons. The official tension shear weight of the wire is 4.13 tons.

⑥ Eyebolt Portion of $\Phi 12$ Wire
A right-angled crevice and a heart thimble deform but withstand any breakage. The withstanding weight is 9.5 tons. The official tension shear weight of the wire is 9.48 tons.

⑥ Description of Deformed Part
Two pins of right-angled crevice, the lower half of the crevice and a pin-hole of the eyebolt as well as a heart thimble were metamorphosed. The left pin and the lower half of the crevice were severely damaged. The right pin and the eyebolt hole were metamorphosed by about 1mm.

OUTLINE DRAWING

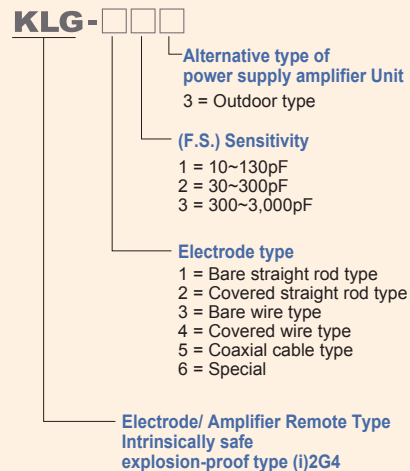
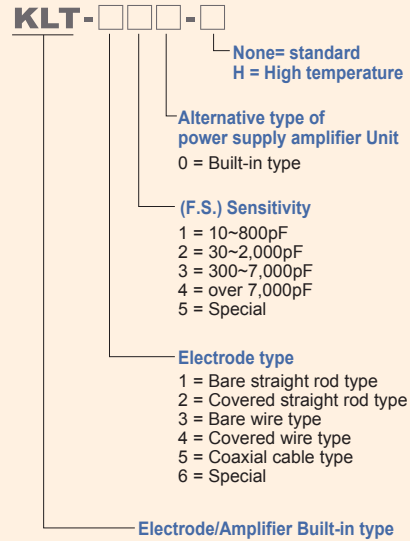
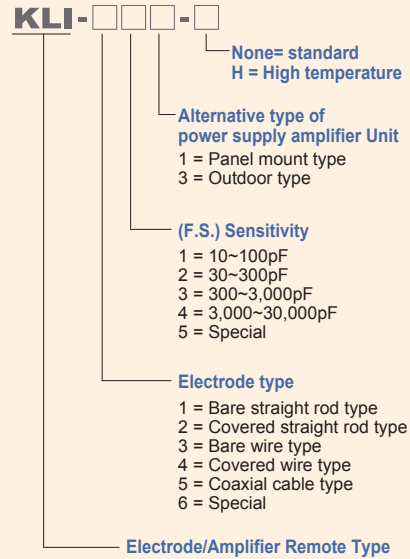

*As for the model of "Pyrex" and "Special", please check with our Sales staff.

Please inform us of the following when inquiring and ordering

| | | |
|---|---|----------|
| 1. Name of material to be measured | [|] |
| 2. Dielectric constant, Specific resistance | [|] |
| 3. Granularity | [|] |
| 4. Viscosity / Agglomerating Nature | [| Yes • No |
| 5. Corrosive Nature | [| Yes • No |
| 6. Foamy Nature | [| Yes • No |
| 7. Tank Material | [|] |
| 8. Tank Shape (1.Circular, 2.Square) | [|] |
| 9. Agitator | [| Yes • No |
| 10. Service Temperature / °C | [| °C |
| 11. Service Pressure / Pa | [| Pa |
| 12. Length of Exclusive Cable (attachment) | [|] |
| 13. Type of Amplifier Housing | [|] |
| 14. Indicator and other ancillary equip. | [| Yes • No |

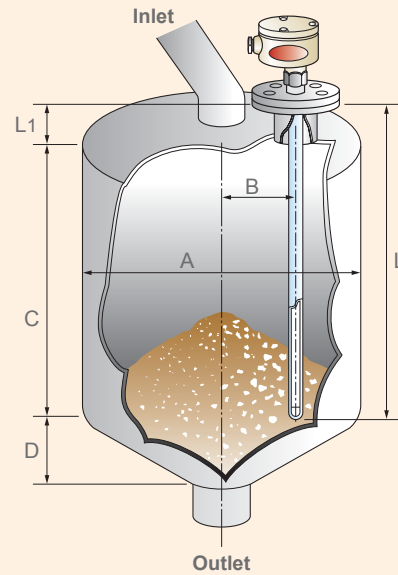

Caution

You may come across some indication errors under the varied conditions as follows:

1. Varied water content of a material to be measured
2. Varied dielectric constant of a material to be measured
3. Varied particle size of a material to be measured

Fill out the following blanks:

| | | |
|-------------------------------------|---|---|
| A Tank Diameter | [|] |
| B Instrument Location | [|] |
| L Length of Electrode | [|] |
| L1 Height of Nozzle installed | [|] |
| ℓ Measuring Span | [|] |
| C Height of Tank's Cylindrical Part | [|] |
| D Height of Tank's Conical Part | [|] |

Line of business

- Rotary Paddle Type Level Switch
- Vibration Type Level Switch
- Swing Type Level Switch
- Acoustic Level Switch
- Capacitance Type Level Switch
- Capacitive Proximity Sensor
- Capacitance Type Level Indicator
- Diaphragm Type Level Switch
- Tilt Switch
- Leak Type Level Switch
- Microwave Switch
- Sounding Bob Type Level Indicator
- Flow Switch
- Conductance Type Level Switch
- Float Switch
- Float Type Level Indicator
- Ultrasonic Type Level Indicator
- Equipments For Conveyor Lines
- Dust Monitor System
- Zirconia Oxygen Analyzer
- Laser Type Level Indicator
- RADAR Type Level Indicator
- On-line Sensors for Accurate Liquid Analysis
- Ultrasonic Flow meter

*Please be sure to read USER'S GUIDE, Installation & Operation Instructions before using the instrument.

*The specifications herein may be subject to change without advance notice.

Nuclear Power Generation to Rice Milling
All-round Manufacturer of Level Controllers for Powder, Granules and Liquid

KANSAI Automation Co.,Ltd.

Headquarters :
2-14, Togano-cho, Kita-ku, Osaka 530-0056, Japan
TEL. 81-6-6312-2071 FAX. 81-6-6314-0848
e-mail: info@kansai-automation.co.jp

<http://www.kansai-automation.co.jp>

Tokyo Branch : 1-29-6, Hamamatsu-cho, Minato-ku, Tokyo 105-0013, Japan
TEL. 81-3-5777-6931 FAX. 81-3-5777-6933

Nagoya Office : 3-31-27, Uchiyama, Chigusa-ku, Nagoya 464-0075, Japan
TEL. 81-52-741-2432 FAX. 81-52-741-1588

Kyushu Office : 1-2-39, Asano, Kokura Kita-ku, Kitakyushu 802-0001, Japan
TEL. 81-93-511-4741 FAX. 81-93-511-4580



Design, development, and manufacture of level measuring sensors

Agent